



PELICAN™ CARGO CASE SADDLE MOUNT, FLANGE, GEN 2 (SDDLMT2A)

UNIVERSAL

SINCE 1976



For Pelican™ BX55S, BX85S CARGO Cases in Truck Beds using factory bed-rail mounting.

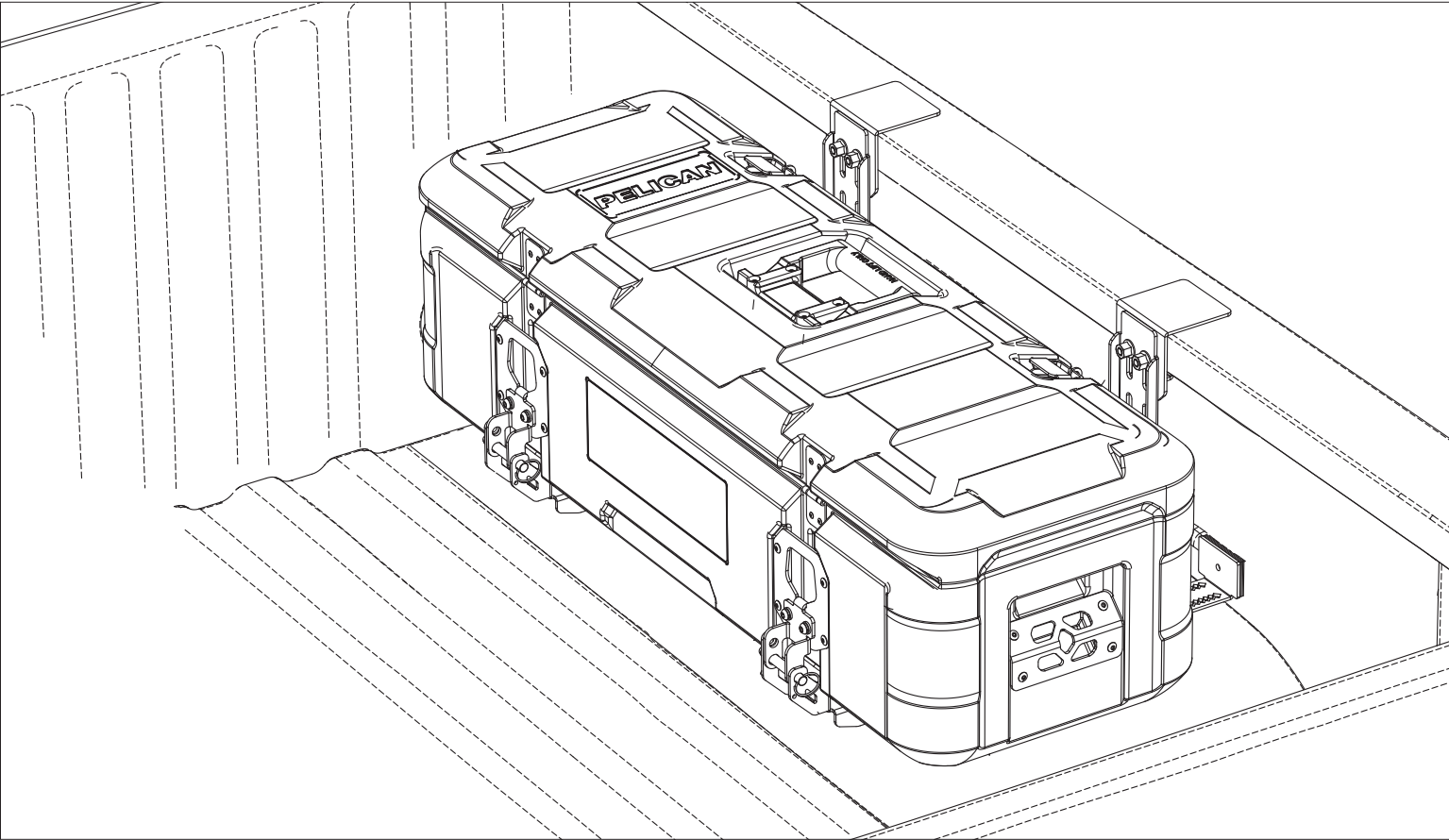

PELICAN™ CARGO CASES AND MOUNTS LIMITED LIFETIME WARRANTY (CASES) AND THREE YEAR WARRANTY (MOUNTS)

Pelican Products, Inc. ("Pelican") guarantees its Pelican™ Cargo cases for a lifetime against breakage or defects in workmanship. This lifetime warranty does not cover mounting hardware, which Pelican warrants against defects in materials and workmanship for three years from the date of purchase. To the extent permitted by law, Pelican's liability is limited to the case and not its contents and in no event shall Pelican's liability to the purchaser for damages exceed the purchase price of the case in respect of which damages are claimed.

TO THE EXTENT PERMITTED BY LAW: (A) THIS WARRANTY IS IN LIEU OF ALL WARRANTIES, EXPRESS OR IMPLIED, INCLUDING, BUT NOT LIMITED TO, THE IMPLIED WARRANTIES OF MERCHANTABILITY AND FITNESS FOR A PARTICULAR PURPOSE; (B) ALL OTHER IMPLIED WARRANTIES AND ANY LIABILITY NOT BASED UPON CONTRACT ARE HEREBY DISCLAIMED AND EXCLUDED; AND (C) IN NO EVENT SHALL PELICAN BE LIABLE FOR ANY INDIRECT, PUNITIVE, INCIDENTAL OR CONSEQUENTIAL DAMAGES, OR SPECIAL DAMAGES, REGARDLESS OF WHETHER A CLAIM FOR SUCH DAMAGES IS BASED ON WARRANTY, CONTRACT, NEGLIGENCE OR OTHERWISE.

With valid dated proof of purchase, Pelican will either repair or replace any broken or defective product, at our sole option. Certain products are available for a limited time only. If a claim is made involving one of these products, Pelican reserves the right to replace a broken or defective product with a standard Pelican product of comparable size and quality if no comparable limited edition product is available at the time of a claim. TO THE EXTENT PERMITTED BY LAW, THIS SHALL BE THE SOLE AND EXCLUSIVE REMEDY OF THE PURCHASER.

To make a warranty claim, the purchaser must complete the warranty claim form at <https://www.pelican.com/us/en/support/warranty/>. Any warranty claims shall be made by the purchaser as soon as practicable and, with respect to the mounts and related hardware, no later than three years from the date of purchase. The purchaser must provide valid dated proof of purchase and obtain a return authorization number from Pelican Customer Service prior to returning any product, and is responsible for paying for all warranty freight costs. If Pelican determines that any returned product is not defective, within the terms of this warranty, the purchaser shall pay Pelican all costs of handling, return freight and repairs at Pelican's prevailing rates.

This warranty does not cover normal wear and tear including but not limited to scratches, dents or tears, aesthetic surface damage which may be caused by oxidation or by the natural breakdown of colors caused by exposure to the elements. All warranty claims of any nature are barred if the product has been altered, damaged or in any way physically changed, or subjected to abuse, misuse, negligence or accident.

Some states and countries do not allow limitations on how long an implied warranty lasts or the exclusion or limitation of incidental or consequential damages, so the above limitation or exclusion may not apply to you. This warranty gives you specific legal rights, and you may have other rights which vary from state to state and country to country.

In Australia: The benefits provided to you under this warranty are in addition to your rights and remedies as a consumer under the Australian Consumer Law as contained in the Competition and Consumer Act 2010 (Cth) ("the Act"). Nothing in this warranty limits the rights or obligations of a party under the Act in relation to the supply to consumers of goods which cannot be limited, modified or excluded. If applicable, our goods come with guarantees that cannot be excluded under the Act. Consumers are entitled to a replacement or refund for a major failure and compensation for any other reasonably foreseeable loss or damage. Consumers are also entitled to have the goods repaired or replaced if the goods fail to be of acceptable quality and the failure does not amount to a major failure. If you are not a consumer under the Act, then your rights may be limited. To make a warranty claim, the purchaser may contact Pelican Products Australia, Suite 2.33, West Wing, Platinum Bldg., Erina NSW 2250, Tel: +612 4367 7022, or email: info.australia@pelican.com. Any claims should be made as soon as practicable. To expedite claims, the purchaser should obtain a return authorization number from Pelican Customer Service prior to returning any product. The purchaser is responsible for paying for all freight costs. If Pelican determines that any returned product is not defective, within the terms of this warranty or the Act, the purchaser may pay Pelican all costs of handling, return freight and repairs at Pelican's prevailing rates. In the event that Pelican determines that any returned product is defective, within the terms of this warranty or the Act, Pelican shall pay the purchaser all reasonable costs of the purchaser in making a claim under this warranty.



READ ME!

THANK YOU FOR PURCHASING A PELICAN™ CARGO CASE SADDLE MOUNTING KIT. BEFORE YOU START, TAKE A MOMENT TO FAMILIARIZE YOURSELF WITH THE FITTING INSTRUCTIONS AND THE COMPONENTS RECEIVED. REFER TO PAGE 1 FOR A LIST OF ALL THE COMPONENTS, QUANTITIES AND TOOLS REQUIRED.

- NOTE: CASE MAY BE MOUNTED ON HINGE OR LATCH SIDE, ACCORDING TO ACCESS PREFERENCE- FROM OUTSIDE OR MIDDLE OF RACK.



IMPORTANT WARNING!

It is critical that Pelican™ Cargo Mounts and Cases be properly installed and securely attached to your vehicle. Failure to properly secure the Mounts and Cargo Cases to your vehicle could result in serious injury and even death. You are responsible for the fitment of the Mounts and Cargo Cases to your vehicle. You must therefore periodically inspect the equipment for wear and damage. Replace if in doubt. If you have limited mechanical experience you should not attempt to install the equipment. You should have the equipment installed by a professional installer if you have any doubts about your abilities.

It is imperative that the user check the fit security of the cases to the vehicle after an initial brief period of driving and adjust if required. Pelican recommends the user do so periodically and if road conditions change (i.e. freeway to dirt "road"), again check the fit security of the attachment of the Case to the vehicle.



LATCHES AND MOUNTING KIT CARE

Periodically check the latches and mounting hardware to ensure there are no loose parts. Continual exposure to daylight may cause the black hardware finish to dull. To maintain the glossy finish, occasionally apply a light coat of UV protectant. After exposure to salty coastal climates or snowy regions, rinse off the mounts with water to remove salt deposits. To help prevent corrosion, apply a non-reactive silicone-based oil or spray to nuts and bolts. Take care not to damage painted surfaces during mounting and dismounting. Touch-up paint is recommended as needed to prevent corrosion.

PARTS LIST

ITEM NO.	DESCRIPTION	QTY.
1	SADDLE MOUNT BRACKET SUBASSEMBLY, FLANGE	2
2	CASE PLATE CLAMP	2
3	QUICK-RELEASE PIN	2
4	LANYARD	2
5	M6-1.0 X 16 CARRIAGE BOLT	4
6	M6-1.0 NYLON LOCK FLANGE NUT	4
7	M6-1.0 X 14 BUTTON HEAD HEX DRIVE SCREW	4
8	M6 FLAT WASHER	4
9	M6 SPLIT LOCK WASHER	4
10	L-BRACKET	2
11	FLANGE CLAMP	2
12	FOOT	2
13	DUAL-LOCK SNAP STRIP, ADHESIVE BACK	4
14	M8 X 30 CARRIAGE BOLT	4
15	M6 NYLON RETAINER WASHER	4
16	M8 NYLON LOCKNUT	4
17	THREADED DETENT KNOB	2

TOOLS REQUIRED*

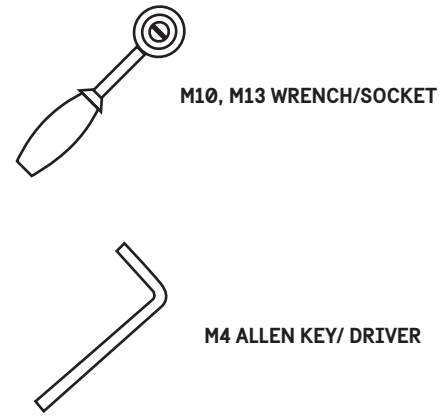

* Tools not included.

1.1

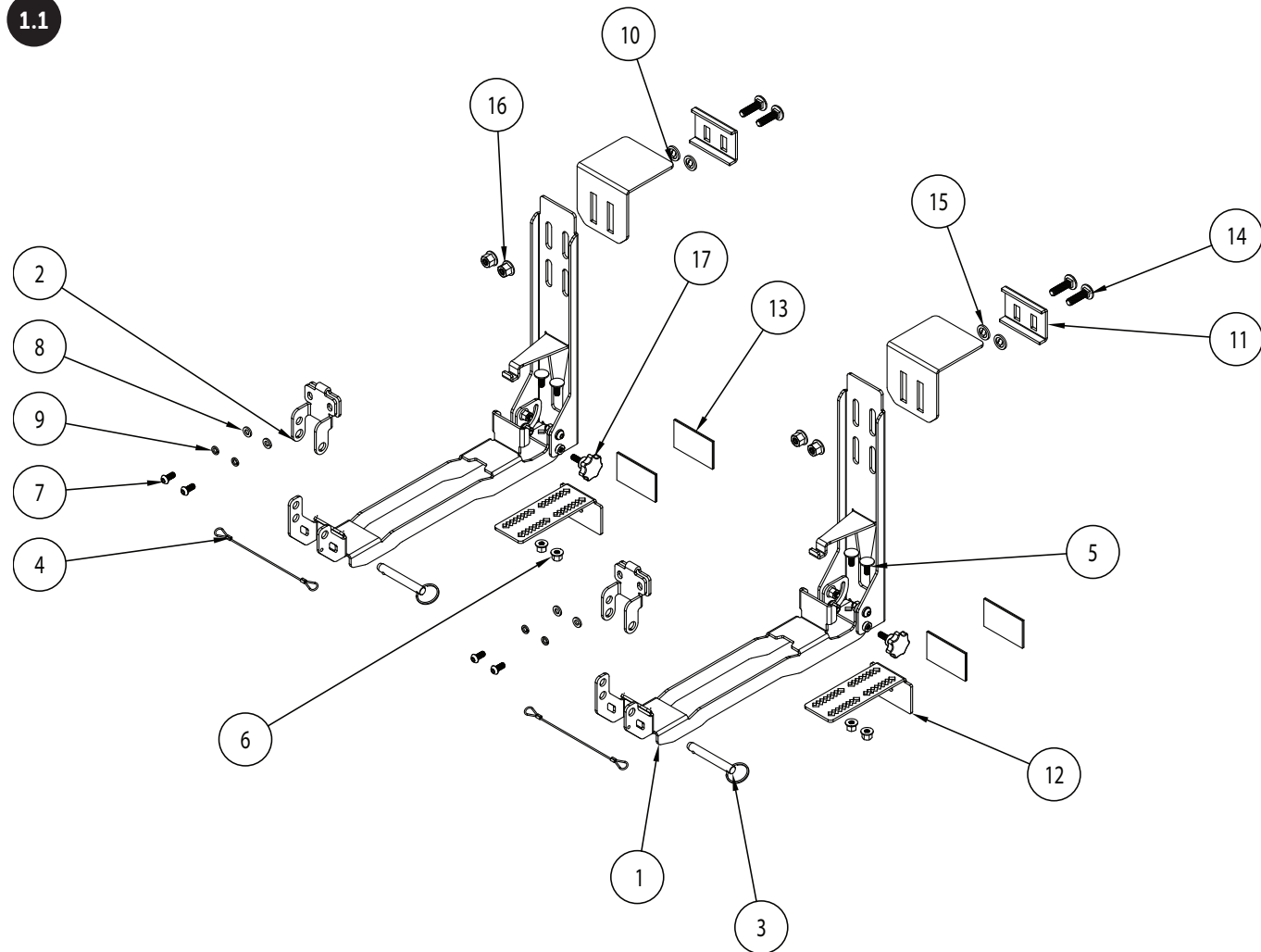

PREFERRED MOUNTING IS ON HINGED SIDE OF CASE, FOR OPENING CASE LID FROM OUTSIDE OF TRUCK BED.

USING M4 ALLEN DRIVE TOOL, ASSEMBLE CLAMPS TO PLATES USING M6 SCREWS, WITH LOCK WASHERS AND FLAT WASHERS AS SHOWN. PARTIALLY TIGHTEN SCREWS TO ALLOW FINAL ADJUSTMENT.

REPEAT FOR 2ND MOUNTING PLATE ON SAME SIDE OF CASE.

2.1

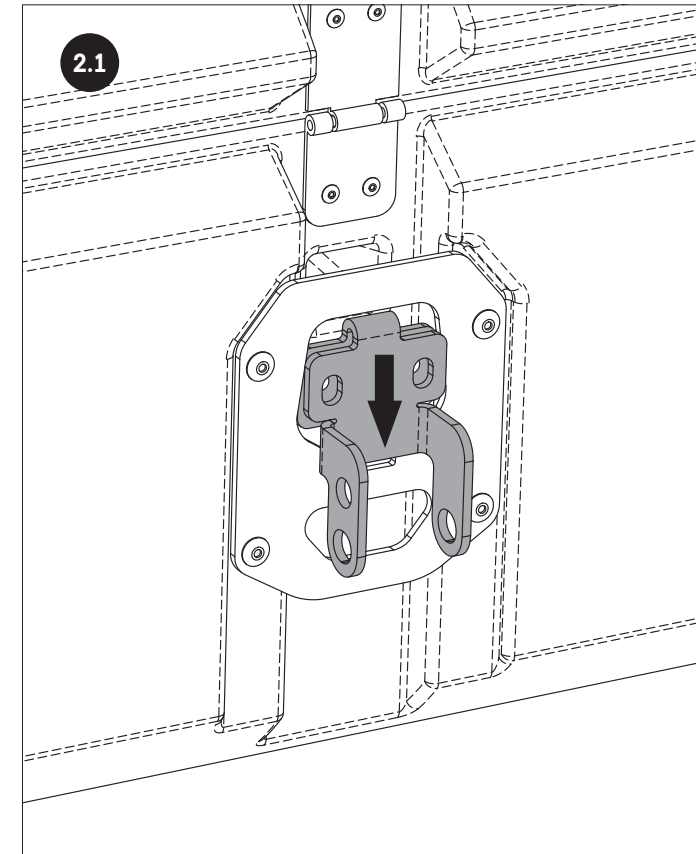

2.2

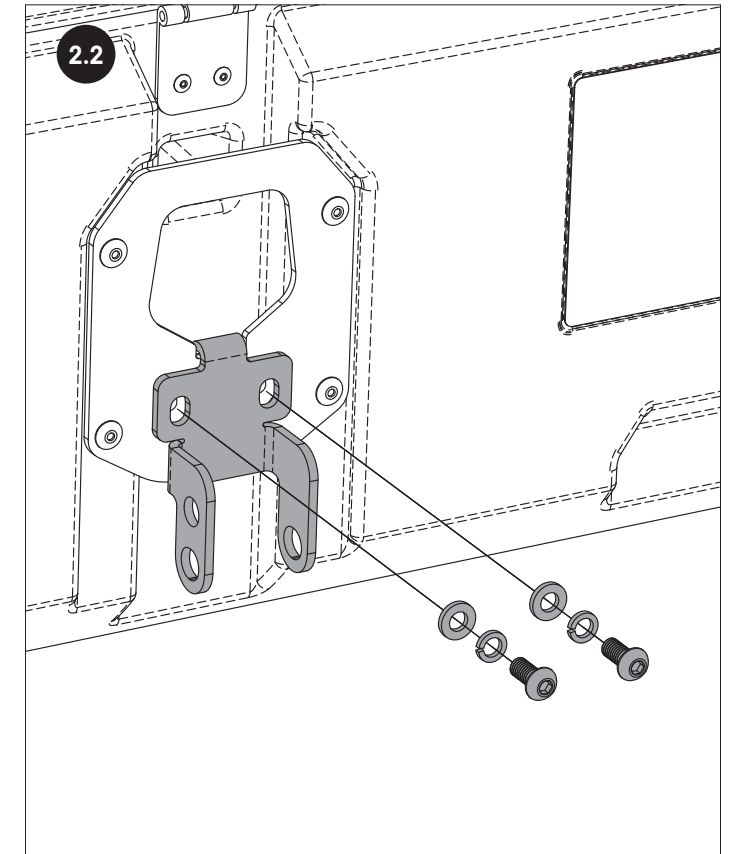

2.3

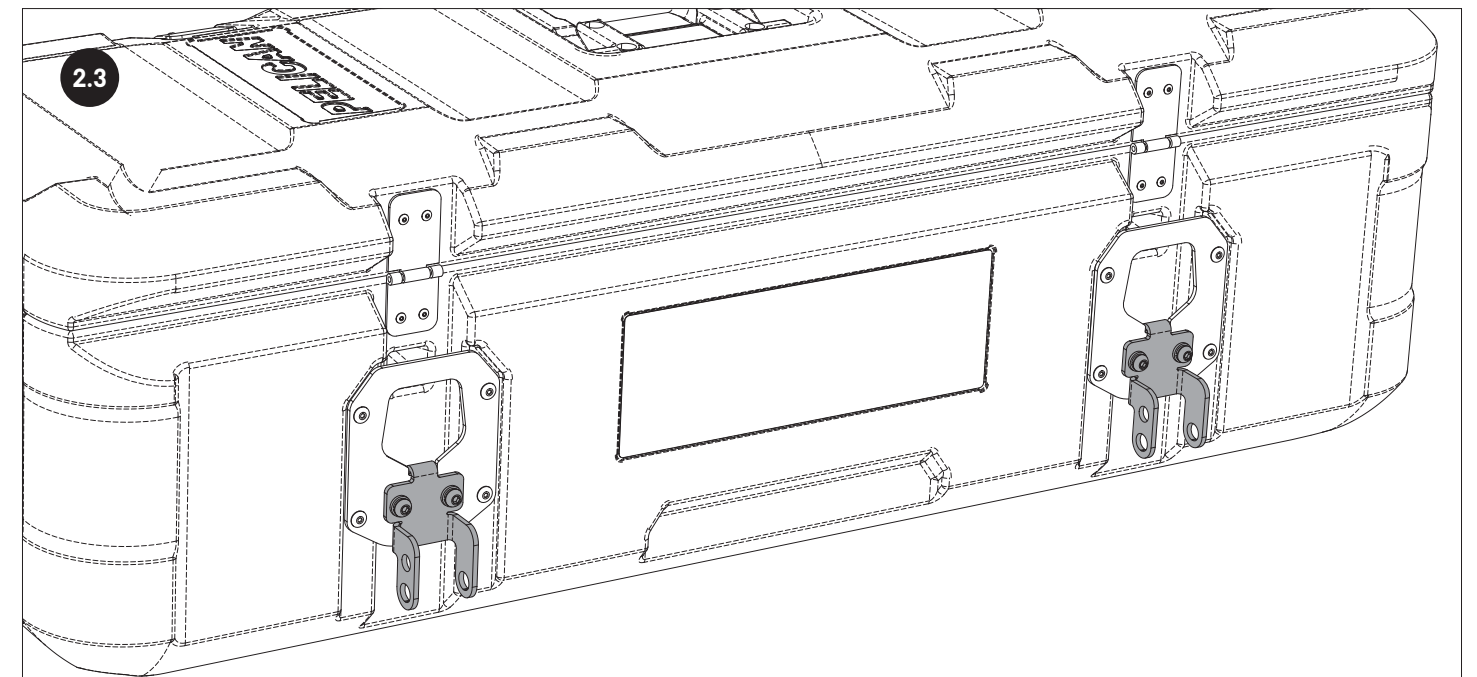

3 ASSEMBLE AND ADJUST FEET



3.1

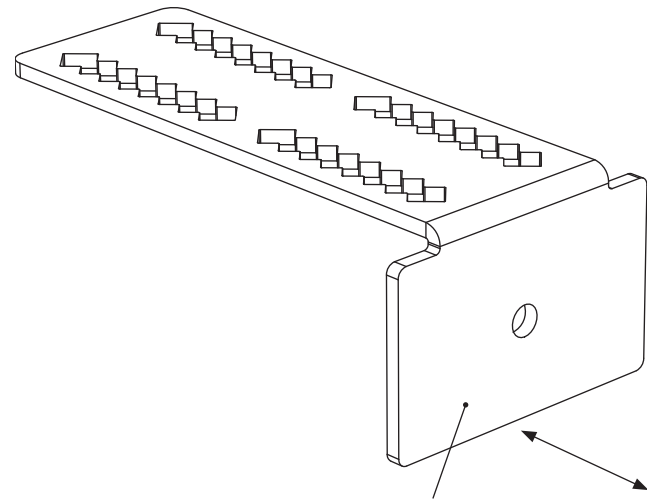

PRESS TWO (2) BLACK SNAP FACES TIGHTLY TOGETHER.
REMOVE TAPE LINER ON ONLY ONE SIDE.
ENSURE MOUNTING FOOT SURFACE IS CLEAN AND DEGREASED. LINE UP TAPE SQUARE TO FOOT.
PRESS THIS ADHESIVE FACE FIRMLY ON ADJUSTABLE FOOT.
LEAVE TAPE LINER ON OTHER SIDE FOR NOW.
TAKE CARE TO NOT TOUCH ADHESIVE SURFACE WITH HANDS OR OBJECTS.

Remove the adhesive liner. Firmly press adhesive side to face of mounting foot.

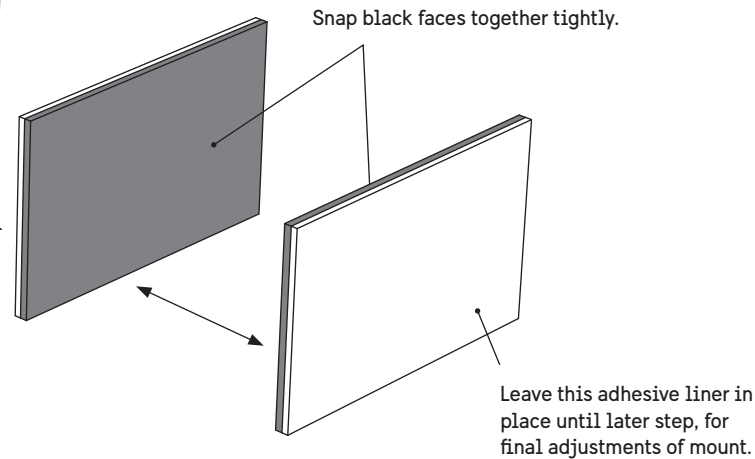

3.2

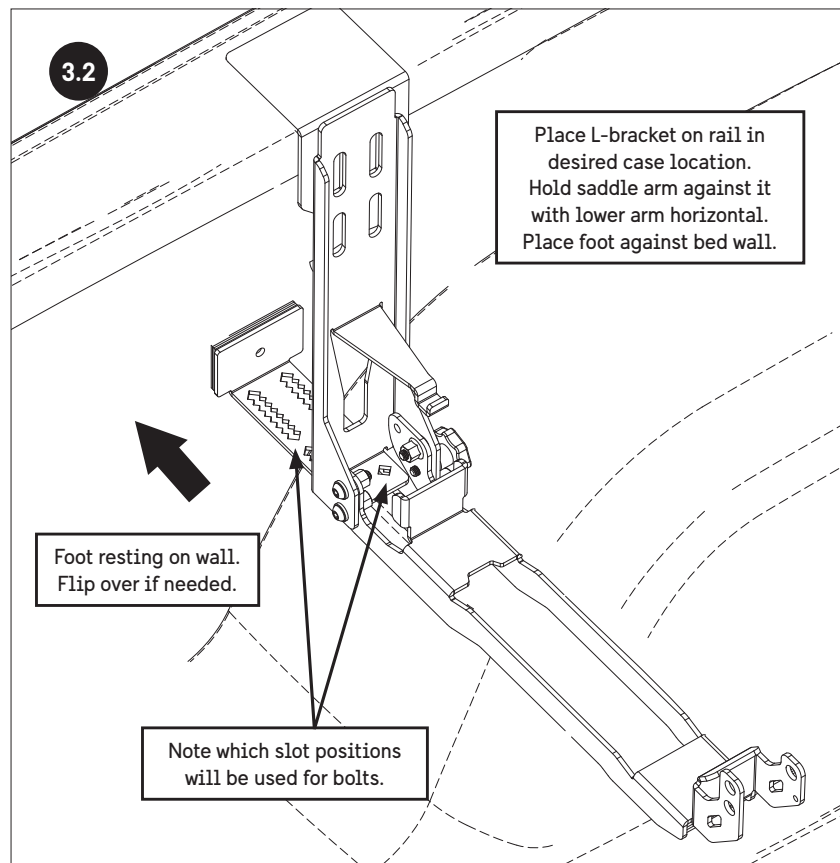

TEMPORARILY HOLD SADDLE ARM IN TRUCK BED TO DETERMINE FOOT LENGTH ADJUSTMENT.
THIS MAY VARY BETWEEN THE TWO SADDLE ARMS, OR NEED FINE ADJUSTMENT LATER.

3 ASSEMBLE AND ADJUST FEET

3.3

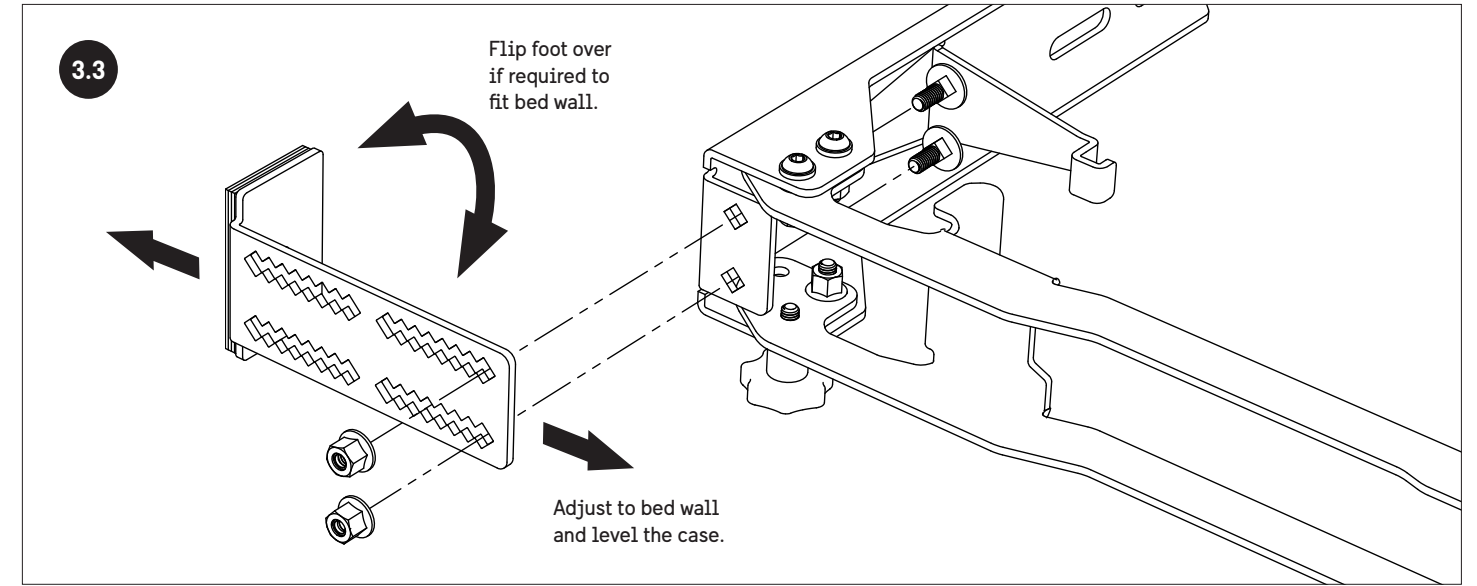

FIT M6 BOLTS THROUGH SQUARE HOLES IN SADDLE ARM.
PARTIALLY TIGHTEN M6 LOCKNUTS, FOR FINAL ADJUSTMENT LATER.

3.4

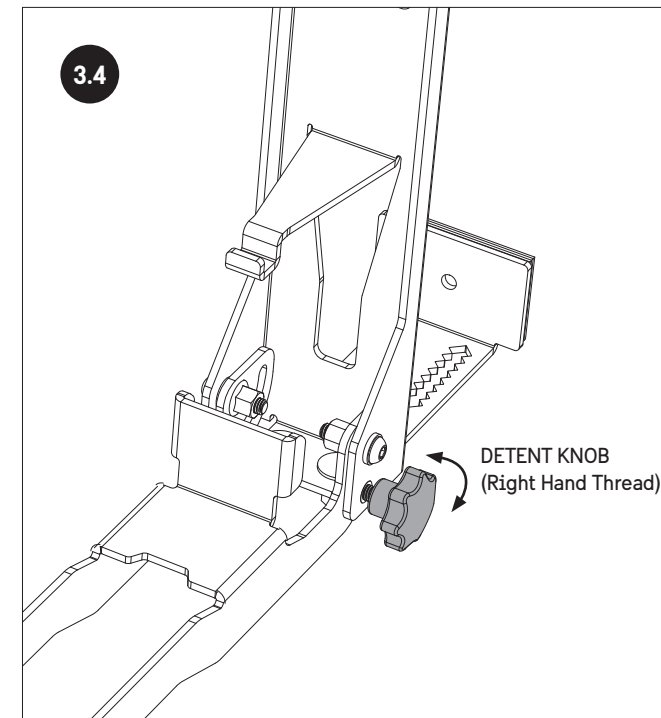

INSERT DETENT KNOB WITH LOWER ARM HORIZONTAL
KNOB MUST BE THREADED FULLY IN, TO LOCK ARM HORIZONTALLY FOR SUPPORTING CASE.
REPEAT STEPS 3.1 - 3.4 FOR OTHER MOUNT SUBASSEMBLY.
TO AVOID SCRATCHING PAINT ON LOWER ARM, TAKE CARE TO ALWAYS UNTHREAD KNOB SUFFICIENTLY TO CLEAR LOWER ARM BEFORE ROTATING.

3.5

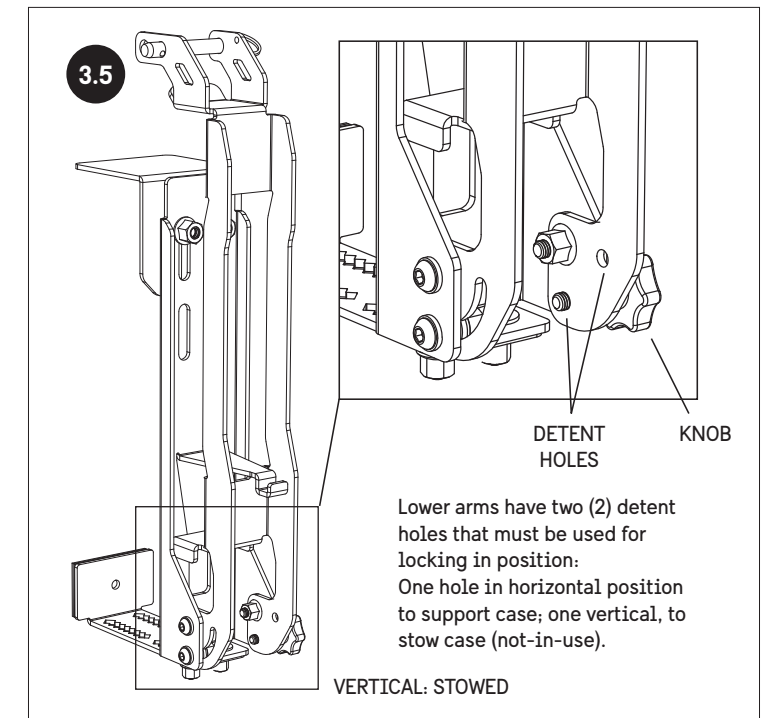

4 ASSEMBLE FLANGE CLAMPS

4.1

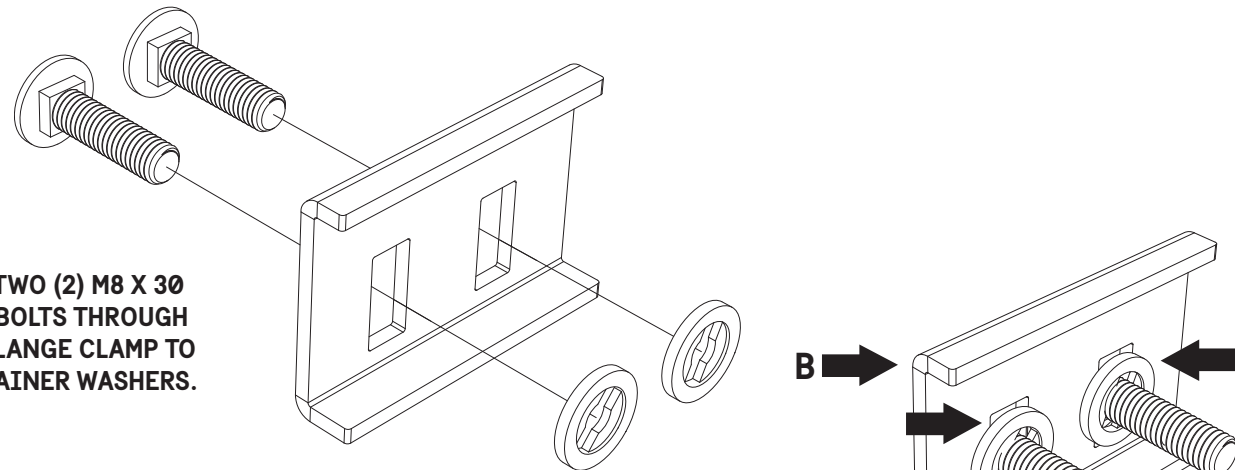

ASSEMBLE TWO (2) M8 X 30 CARRIAGE BOLTS THROUGH SLOTS IN FLANGE CLAMP TO NYLON RETAINER WASHERS.

SLIDE NYLON RETAINER WASHERS FIRMLY AGAINST FLANGE CLAMP AND TIGHTLY SEAT SQUARE BOLT FEATURES IN SLOTS AS SHOWN.

NOTE LEG "B" IS SHORTER THAN "A" AND SHOULD BE AT TOP WHEN INSTALLED IN TRUCK. FLANGE SLOTS WILL BE TOWARDS BOTTOM.

REPEAT FOR OTHER MOUNT SUBASSEMBLY.

REST L-BRACKETS ON BED RAIL.

SLIDE FLANGE CLAMP ASSEMBLIES UP BEHIND RAIL FLANGE.

ADJUST VERTICAL SADDLE ARM SLOTS FOR CASE HEIGHT AND WHEEL WELL CLEARANCE.

FIT BOLTS THROUGH SLOTS IN L-BRACKETS AND SADDLE ARMS.

PARTIALLY TIGHTEN M8 LOCKNUTS TO ALLOW FINAL ADJUSTMENT.

4.2

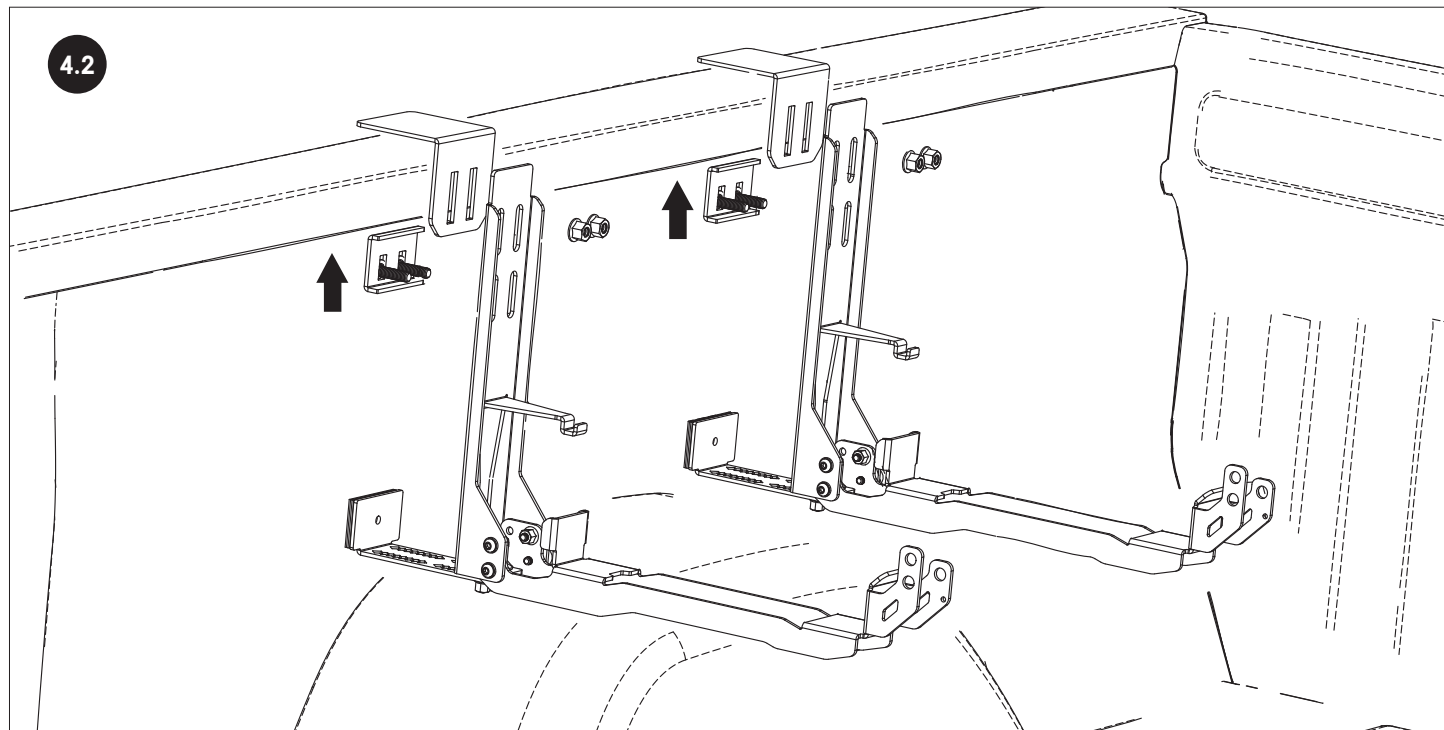

4 MOUNT SADDLE ARM SUBASSEMBLIES TO TRUCK BED RAIL



DETERMINE LOCATION ALONG RAIL FOR CASE.

ADJUST SADDLE ARMS TO MATCH THE MOUNTING PLATE SPACING OF YOUR CASE.

CLEAN AND DEGREASE BED WALL BEHIND SADDLE MOUNT FEET.

PEEL OFF TAPE LINERS TO ADHERE FEET TO BED WALL IN FINAL POSITION.

PUSH FEET FIRMLY AGAINST BED WALL TO ENSURE TAPE ADHESION AND SNAP STRIP MATING.

THIS WILL ASSIST IN HOLDING SADDLE ARMS FOR STEP 4.4.

4.3

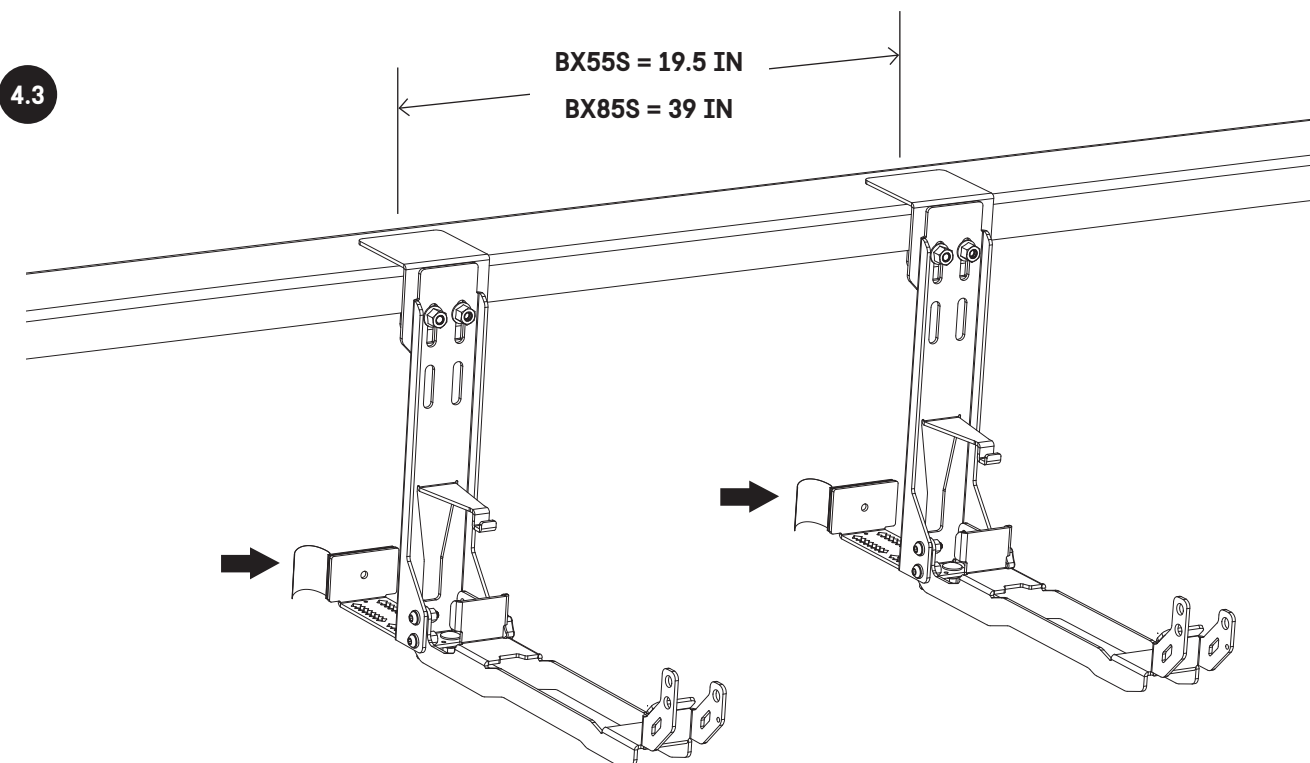

4.4

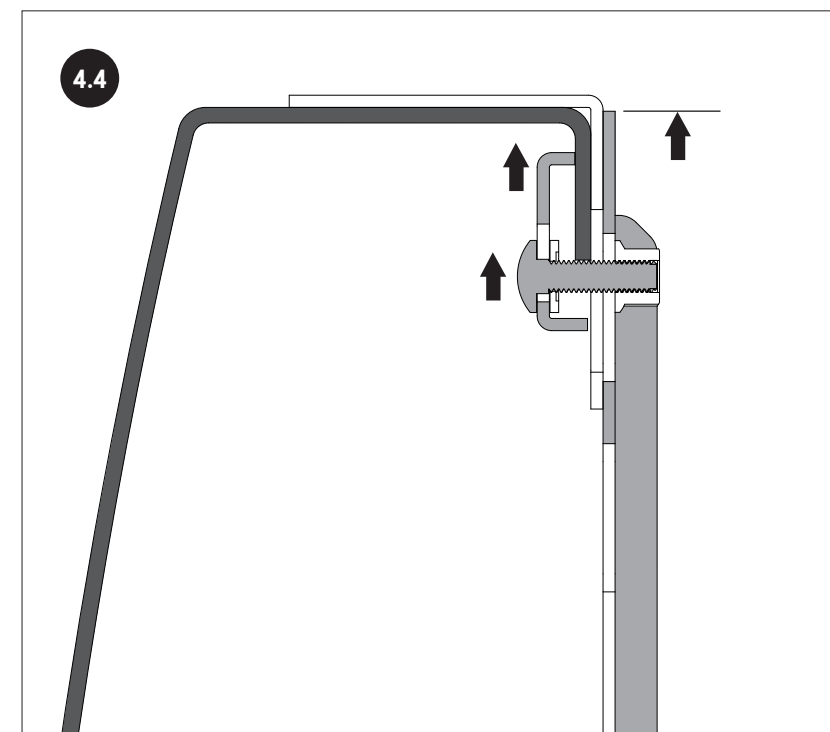

SLIDE FLANGE CLAMPS AND BOLTS UP AS HIGH AS POSSIBLE ON BED-RAIL.

HOLD SADDLE ARM IN FINAL POSITION AND TIGHTEN M8 NUTS TO SECURE.

5 LOADING CARGO CASE ON SADDLE MOUNTS

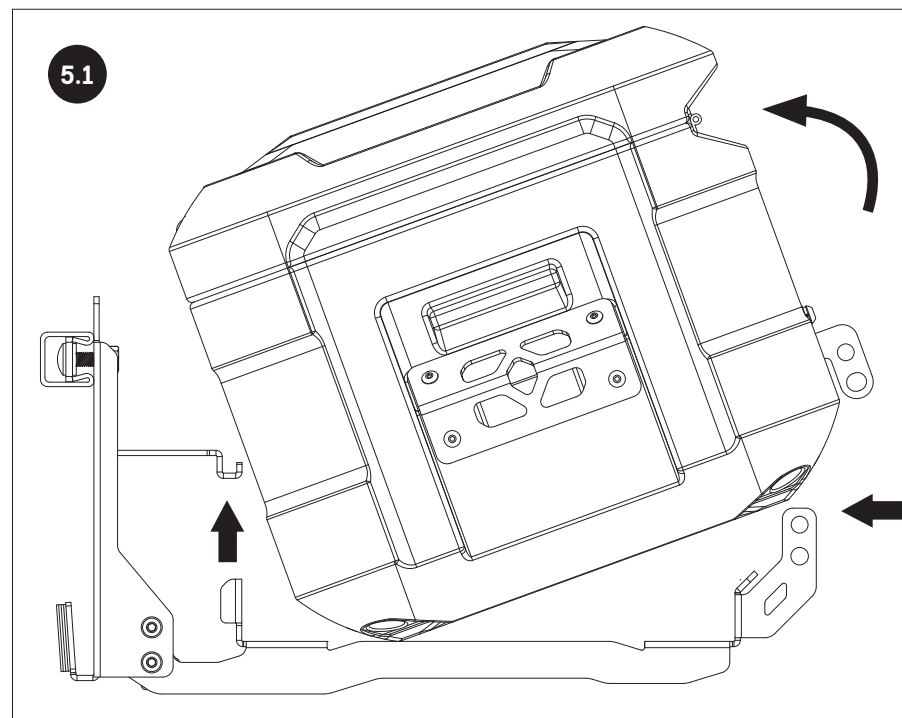

TILT CASE 20 DEGREES AND LOWER REAR EDGE TO REST ON SADDLE ARMS.

BY CLEARING THE ARMS AT THE FRONT, THE REAR HOOKS WILL ALSO CLEAR THE PLATES.

SLIDE CASE BACK AGAINST UPRIGHTS TO ENGAGE HOOKS.

TILT CASE DOWN TO REST IN HORIZONTAL POSITION.

CLEARING REAR HOOKS

CHECK BOTH REAR HOOKS ARE NOW ENGAGED

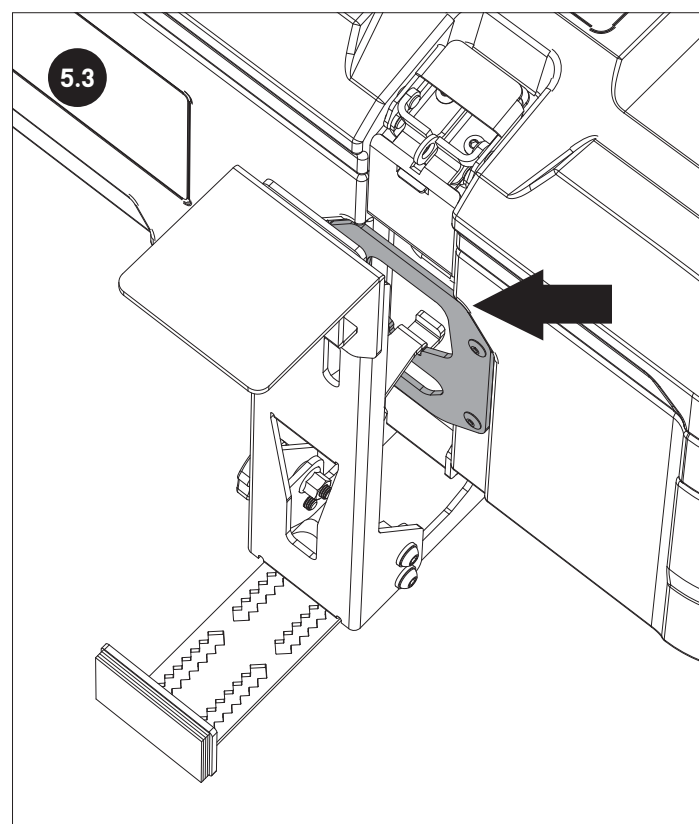
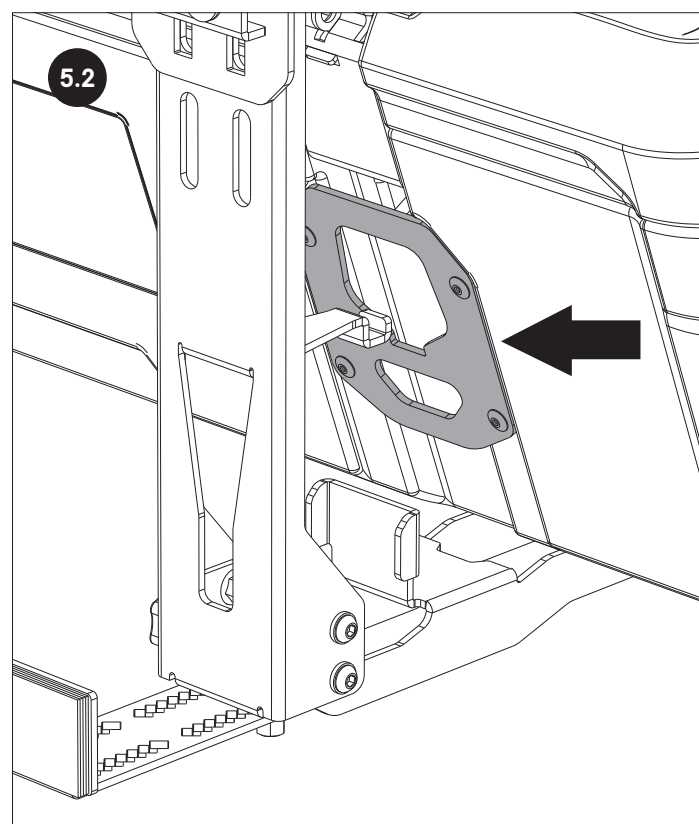

6 ADJUST AND TIGHTEN PLATE CLAMPS



1. WITH PIN INSERTED AND FASTENERS LOOSENED, ADJUST PLATE CLAMP POSITION TO CENTER AND ALLOW EASY PIN REMOVAL/INSERTION.
2. TIGHTEN SCREWS WITH M4 ALLEN TOOL.

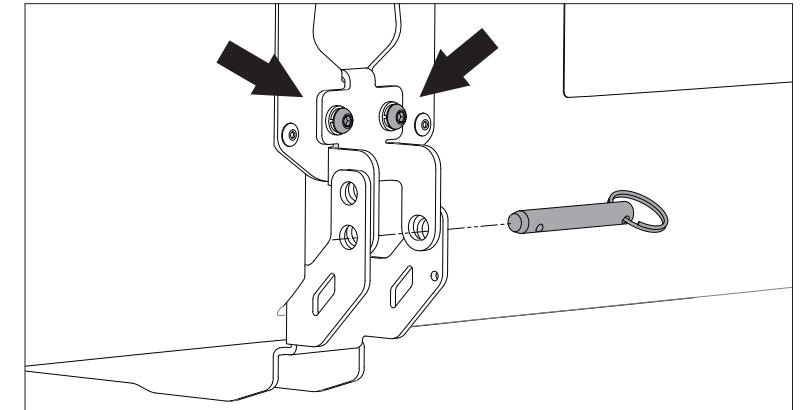

7 ASSEMBLE LANYARDS TO LOWER SADDLE ARMS

1. SQUEEZE END OF LANYARD AND PUSH THROUGH HOLE IN PINNED YOKE.

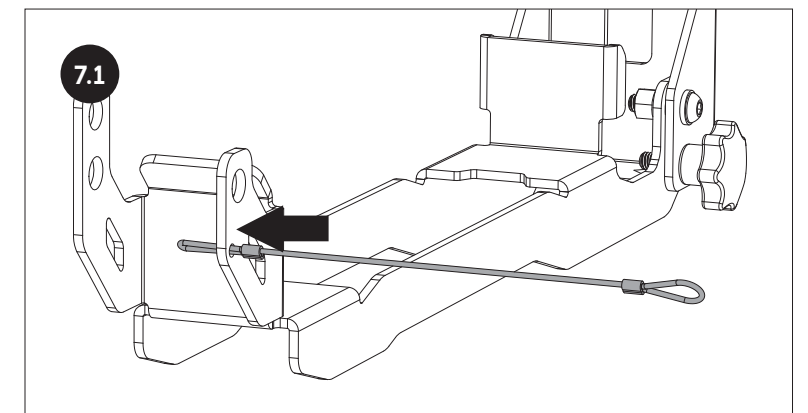

2. FEED OTHER END BACK THROUGH LOOP. PUSH PAST CRIMP EDGE TO SECURE, AS SHOWN.

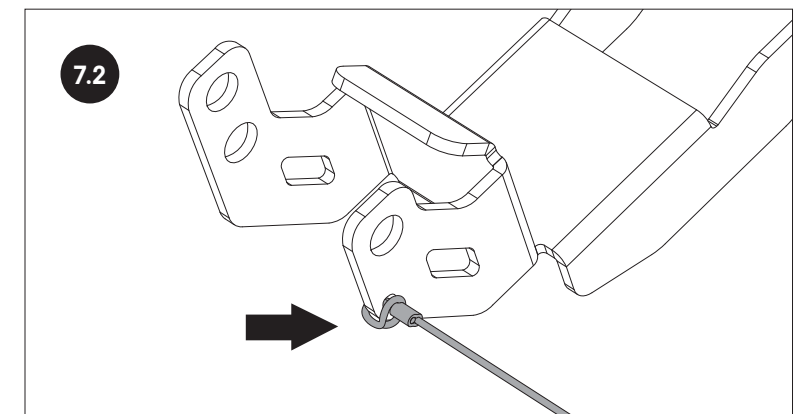

3. ATTACH LOOSE END TO KEY-RING OF QUICK RELEASE PIN. REPEAT FOR OTHER LANYARD.

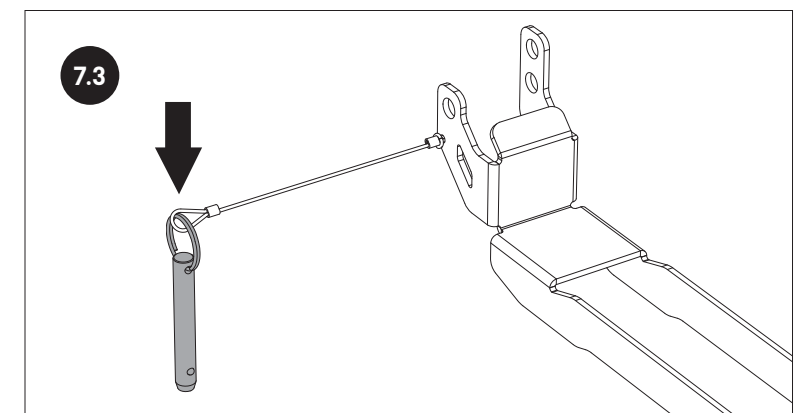

**TO SECURE CARGO CASE
AGAINST THEFT**

PADLOCK ONE OR BOTH MOUNTS
(PADLOCK SOLD SEPARATELY).

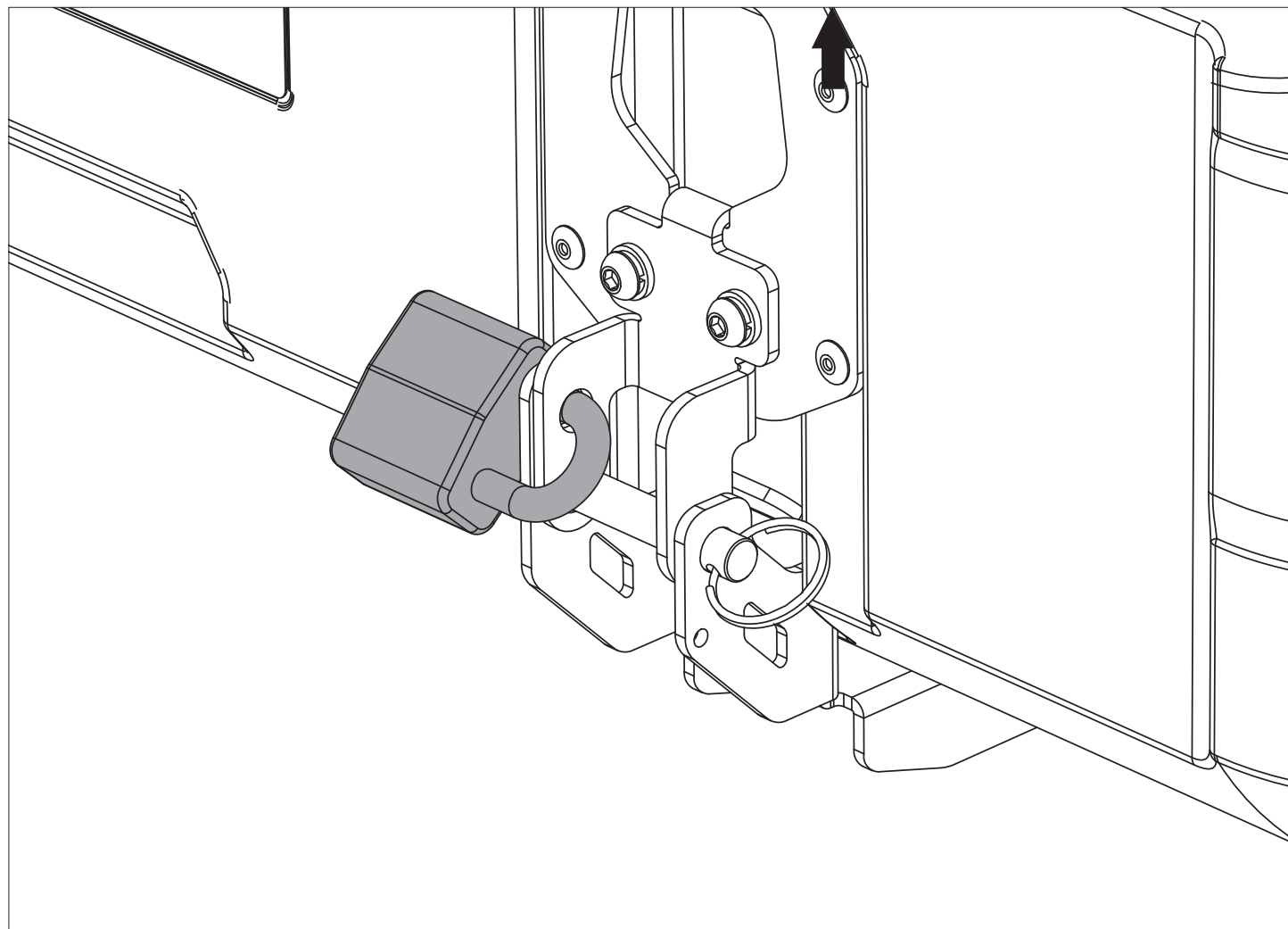

9.1

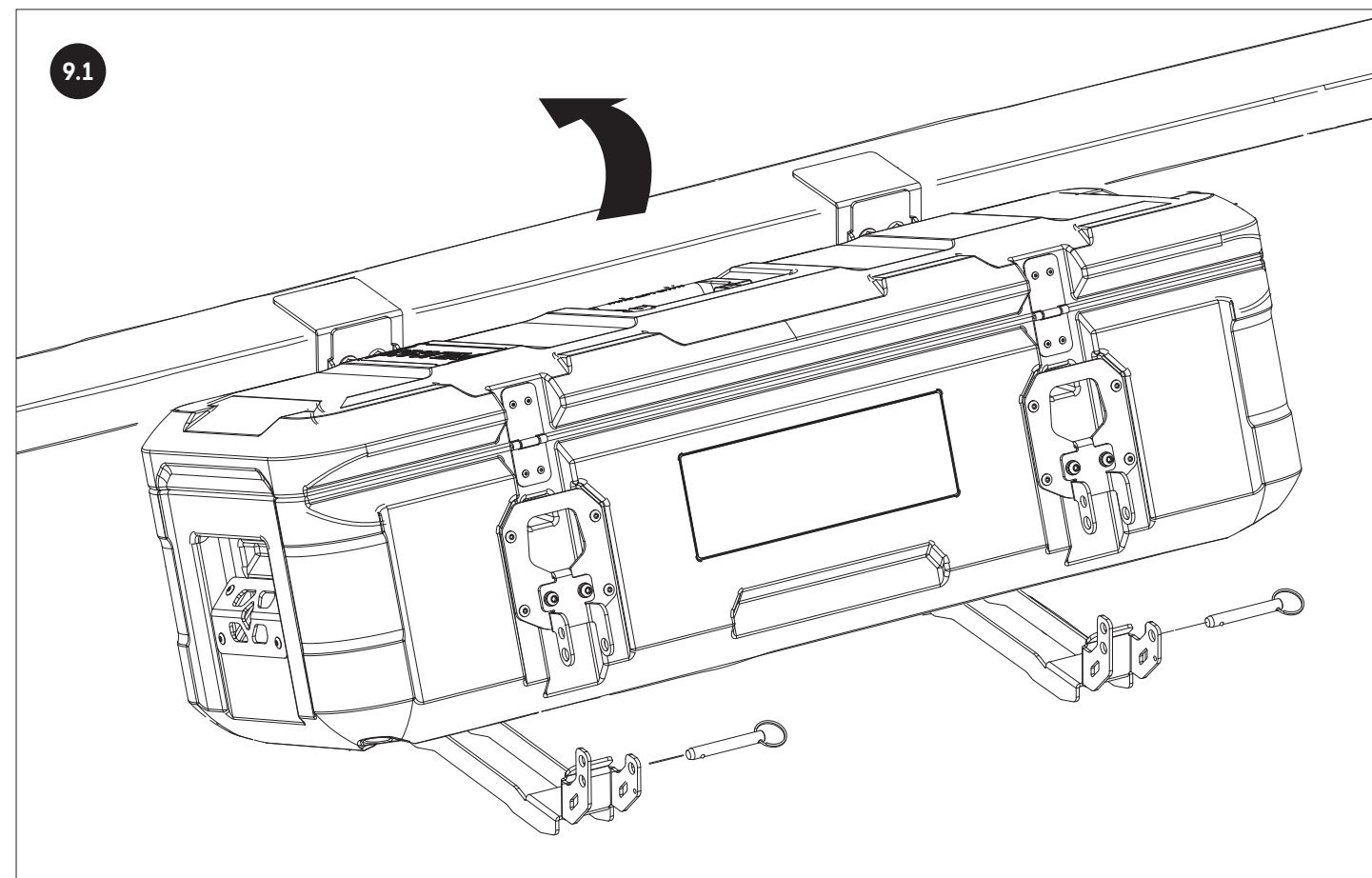

9.2

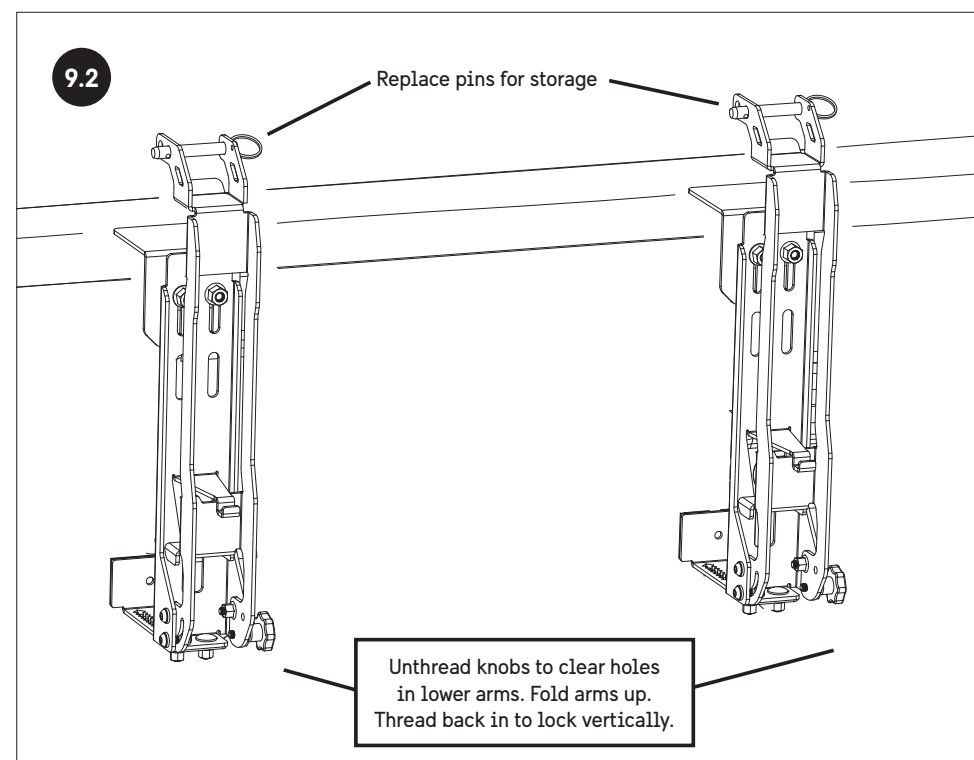

SLIDE PINS OUT AND
TILT CASE UP AND OUT.

UNTHREAD DETENT KNOBS
SUFFICIENTLY TO CLEAR
LOWER ARMS.

SWING ARMS UP TO THE
VERTICAL POSITION.

LOCK BY FULLY THREADING
KNOBS BACK IN.

REPLACE PINS IN ARMS.

NOW STOWED OUT OF WAY.